

KOMATSU®

PC220-7 PC220LC-7

FLYWHEEL HORSEPOWER

125 kW 168 HP @ 2000 rpm

OPERATING WEIGHT

PC220-7: 22840–23360 kg

50,350–51,500 lb

PC220LC-7: 23990–24550 kg

52,890–54,120 lb



Photo may include optional equipment.

HYDRAULIC EXCAVATOR

JC Machinery

SUNIGHT

excavatorhunter.com

WALK-AROUND

Productivity Features

- **High Production and Low Fuel Consumption**

Production is increased with larger output during Active mode while fuel efficiency is further improved.

- **Maximum Drawbar Pull Increased 16%** offering superb steering and slope climbing performance.

- **Maximum Digging Height is 10 m 32'10"**, a benefit in jobs requiring a longer reach.

See page 4.

- **Bucket Digging Power Is Increased 21%**

Bucket Digging Power = Bucket digging force x bucket speed. Bucket digging force is increased 9% and bucket digging speed is increased 12%, so bucket digging power is increased 21%. (Compared with PC220-6)

Easy Maintenance

- Replacement interval is extended for engine oil, engine oil filter and hydraulic filter
- Remote mounted engine oil filter and fuel drain valve for easy access
- Water separator is standard equipment
- Easier radiator cleaning
- Fuel tank capacity is increased
- BMRC bushings on work equipment extend lubricating interval from 100 hours to 500 hours (optional)

See page 8 and 9.

- **Higher Lifting Capacity**

PC220-7's lateral stability is improved, lifting capacity also increased.

Harmony with Environment

- Low emission engine
A powerful turbocharged and air to air aftercooled Komatsu SAA6D102E-2 provides **125 kW 168 HP**.
 - Economic mode saves fuel consumption
 - Low operation noise
 - Easily recycled design
- See page 5.

Large Comfortable Cab

New PC220-7's cab volume is increased by 14%, offering an exceptionally roomy operating environment

- Highly pressurized cab with optional air conditioner
 - Low noise design
 - Low vibration with cab damper mounting
 - FOG capable with optional bolt-on top guard
- FOG has been renamed to OPG (Operator Protective Guards) top guard level 2 by ISO 10262

See page 6.

Excellent Reliability and Durability

- High rigidity work equipment
- Sturdy frame structure
- Reliable Komatsu manufactured major components
- Highly reliable electronic devices

See page 5.

FLYWHEEL HORSEPOWER
125 kW 168 HP @ 2000 rpm

OPERATING WEIGHT
PC220-7: 22840–23360 kg
50,350–51,500 lb
PC220LC-7: 23990–24550 kg
52,890–54,120 lb

BUCKET CAPACITY
0.72–1.26 m³
0.94–1.65 yd³

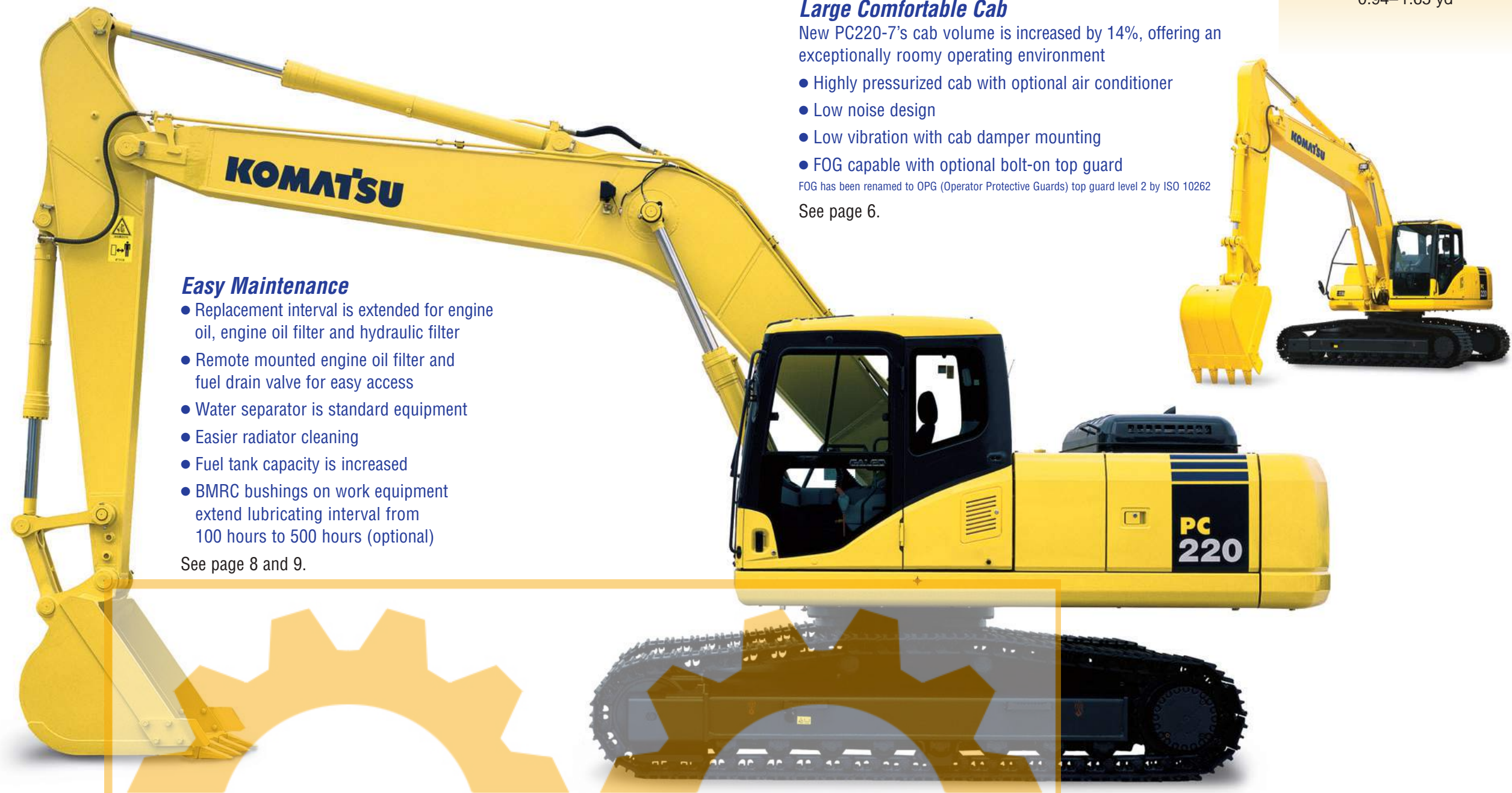

Photo may include optional equipment.

JC Machinery

SUNIGHT

excavatorhunter.com

PRODUCTIVITY FEATURES

High Production and Low Fuel Consumption

The increased output and fuel savings of the Komatsu SAA6D102E-2 engine result in increased production and improved production per unit of fuel.

Engine

The PC220-7 gets its exceptional power and work capacity from a Komatsu SAA6D102E-2 engine. Output is **125 kW** 168 HP, providing increased hydraulic power and improved fuel efficiency.

Hydraulics

Unique two-pump system ensures smooth compound movement of the work equipment. HydrauMind controls both pumps for efficient engine power use. This system also reduces hydraulic loss during operation.

Large Digging Height

PC220-7's maximum digging height is **10 m 32'10"**, facilitating jobs that require a longer reach, such as demolition and slope finishing.

Larger Lifting Capacity

PC220-7's lateral stability is improved, as a result, the PC220-7 lifting capacity is increased. Example: lifting capacity over side (reach **6.1 m 20'**, height **4.6 m 15'**) is increased from **4.45 ton** 4.9 U.S. ton to **4.8 ton** 5.3 U.S. ton.

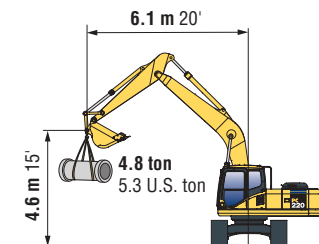

Larger Digging Power Provides Increased Production



Bucket Digging Power is obtained by bucket digging force x bucket digging speed. New PC220-7 bucket digging force is increased by 9% and bucket digging speed is increased by 12%, resulting total bucket digging power is increased 21% (bucket digging force compared with PC220-6). The digging force and speed generated result in the largest digging power and the largest production in the **22 ton** 24 U.S. ton class.

Larger Maximum Drawbar Pull

PC220-7's maximum drawbar pull is increased by 16%, provides superb steering and slope climbing performance.

Maximum drawbar pull: 202 kN **20570 kg** 45,350 lb
 Drawbar pull/operating weight: 0.91

Three Working Modes

Working Mode Selection

The PC220-7 excavator is equipped with three working modes (**A**, **E** and **B** mode). Each mode is designed to match engine speed, pump speed, and system pressure with the current application. This provides the flexibility to match equipment performance to the job at hand.

Working Mode	Application	Advantage
A	Active mode	<ul style="list-style-type: none"> Maximum production/power Fast cycle times
E	Economy mode	<ul style="list-style-type: none"> Excellent fuel economy
B	Breaker operation	<ul style="list-style-type: none"> Optimum engine rpm, hydraulic flow

Economy Mode

Economy mode is environmentally friendly. Fuel consumption is reduced 16% (compared with PC220-7 Active mode) and production is equal to the PC220-6 Heavy-duty mode.

Power Max Function

This function temporarily increases digging force by 7% for added power in tough situations.

Excellent Reliability and Durability

High Rigidity Work Equipment

The arm and boom are strengthened to correspond to increasing bucket and arm digging forces. The arm and boom cross sectional strength are also increased 25% and 8% respectively. The boom and arm have large cross-sectional dimensions as well as continuous groove welding, improving digging and side-contact strength.

Sturdy Frame Structure

The revolving frame, center frame and undercarriage are designed by using the most advanced three-dimensional CAD and FEM analysis technology.

Reliable Components

All of the major machine components, such as engine, hydraulic pumps, hydraulic motors and control valves, etc., are exclusively designed and manufactured by Komatsu.

Highly Reliable Electronic Devices

Exclusively designed electronic devices have passed severe testing.

- Controller
- Sensors
- Connectors
- Heat resistant wiring

• **Metal guard rings** protect all the hydraulic cylinders and improve reliability.

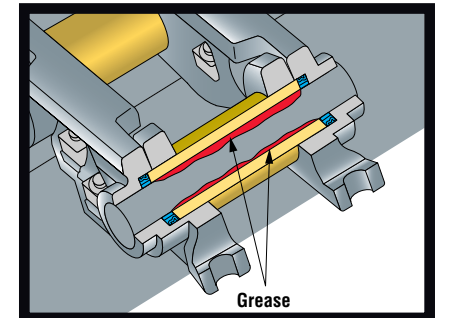
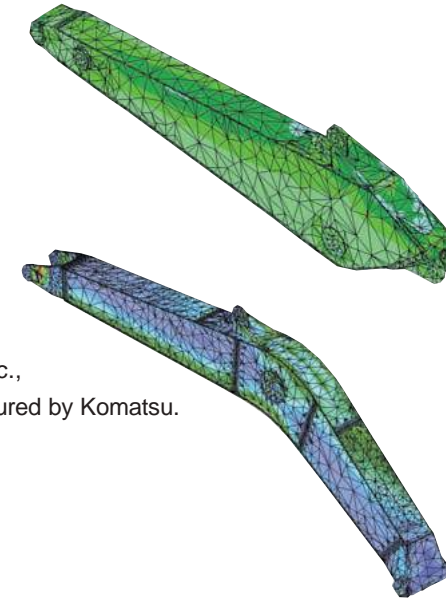

Grease Sealed Track provides excellent undercarriage durability

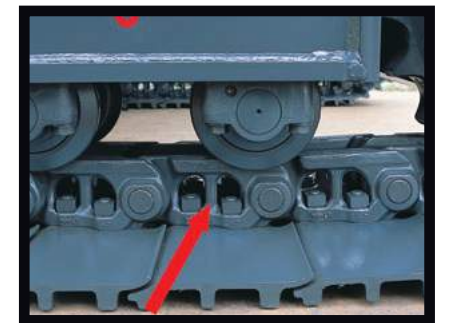

Track Link with Strut
 PC220-7 uses track links with strut providing superb durability

Harmony with Environment

Low Noise

Noise is reduced not only from the engine but also during swing and hydraulic relief. Dynamic noise level is 104 dB.

Environment Oriented Mode (Economy Mode)

Economy mode meets the needs of the 21st century. Economy mode offers the user fuel savings, quiet operation and less CO₂ emission.

- Fuel consumption is reduced 16% (compared with Active mode).
- Production is the same as the PC220-6 Heavy-duty mode.

Easily Recycled

PC220-7 is designed with consideration of recycling and uses natural resources effectively.

- Sound suppressing material is made from PET (polyethylene terephthalate) resin that is easy to recycle.
- All exterior parts are made from steel.
- Engine and hydraulic system oil and filter replacement interval are extended to save earth resources.
- All resin-made parts are indicated by material code symbol.



WORKING ENVIRONMENT

PC220-7 cab interior is spacious and provides a comfortable working environment...

Large Comfortable Cab

Comfortable Cab

New PC220-7's cab volume is increased by 14%, offering an exceptionally comfortable operating environment. The large cab enables full flat reclining of the seat back with headrest.

Pressurized Cab

With optional air conditioner, air filter and a higher internal air pressure (6.0 mm Aq 0.2" Aq) prevent external dust from entering the cab.

Low Noise Design

Noise level is remarkably reduced, not only engine noise but also noise when swinging and hydraulic relief.

Low Vibration with Cab Damper Mounting

PC220-7 uses new, improved multi-layer viscous mount system that incorporates longer stroke and the addition of a spring. The new cab damper mounting combined with strengthened left and right side decks aids vibration reduction at operator seat.

Vibration at floor is reduced from 120 dB (VL) to 115 dB (VL).

dB (VL) is index for expressing size of vibration.

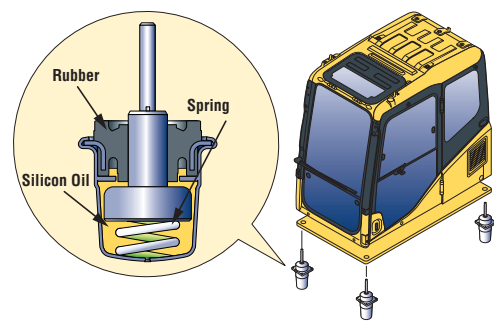

Comparison of Riding Comfort

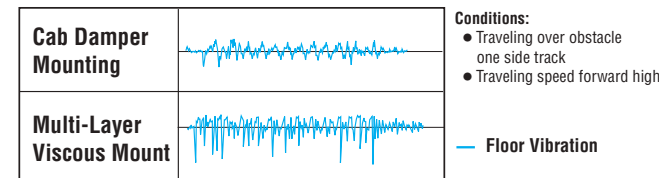

Pitch vertical direction on graph shows size of vibration.



Automatic Air Conditioner (optional)

A 6,900 kcal air conditioner is utilized. The bi-level control function keeps the operator's head and feet cool and warm respectively. This improved air flow function keeps the inside of the cab comfortable throughout the year.

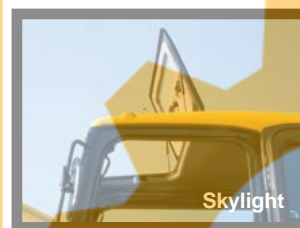
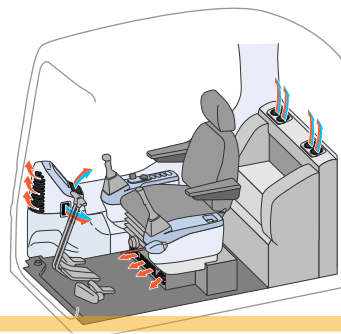

Skylight



Sliding Window



Washable Cab Floor Mat

The PC220-7's cab floor mat is easy to keep clean. The gently inclined surface has a flanged floor mat and drainage holes to facilitate runoff.



Seat with headrest reclined full flat

Photo may include optional equipment.

Multi-Position Controls

The multi-position, pressure proportional control levers allow the operator to work in comfort while maintaining precise control. A double-slide mechanism allows the seat and controllers to move together or independently, allowing the operator to position the controllers for maximum productivity and comfort.



Seat Sliding Amount: 340 mm 13.4", increased 120 mm 4.7"



Defroster (optional)



Cab Frame Mounted Wiper

Safety Features

Cab

FOG capable with optional bolt-on top guard.

Wide Visibility

The right side window pillar has been removed and the rear pillar reshaped to provide better visibility. Blind spots have been decreased by 34%.

Pump/engine room partition

prevents oil from spraying on the engine if a hydraulic hose should burst.

Thermal and fan guards are placed around high-temperature parts of the engine and fan drive.

Steps with non-skid sheet and large handrail. Steps with non-skid sheet provide anti-slip footing for maintenance.



Large Handrail



Thermal Guard and Non-skid Sheet



Bottle Holder and Magazine Rack



MAINTENANCE FEATURES

Self-Diagnostic Monitor

The PC220-7 features the most advanced diagnostics system in the industry. The Komatsu exclusive system identifies maintenance items, reduces diagnostic times, indicates oil and filter replacement hours and displays error codes.

Continuous Machine Monitoring System

When turning starting switch ON, Check-before-starting item and caution items appear on the liquid crystal panel. If abnormalities are found, a warning lamp blinks and a warning buzzer sounds. The continuous machine condition checks help prevent the development of serious problems and allows the operator to concentrate on the controls.

Abnormalities on Electronic System Display with Code

When an error occurs during operation, a user code is displayed. When an important user code is displayed, a caution lamp blinks and a warning buzzer sounds to prevent the development of serious problems.

Oil Maintenance Function

When machine exceeds oil or filter replacement time, oil maintenance monitor lights to inform operator.

Easy Maintenance

Komatsu designed the PC220-7 to have easy service access. We know by doing this, routine maintenance and servicing are less likely to be skipped, which can mean a reduction in costly downtime later on. Here are some of the many service features found on the PC220-7.

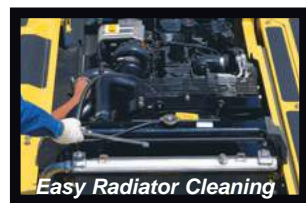

- Easy Radiator Cleaning**
 Clearance between radiator and oil cooler is increased to facilitate radiator core cleaning with an air nozzle.

- Water Separator** is standard equipment, removing water mixed in fuel and preventing fuel system damage.

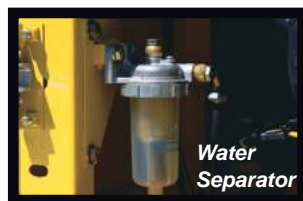

- Self-diagnostic Monitor** allows display of vital self-diagnosis, as well as displaying up to 39 different faults.

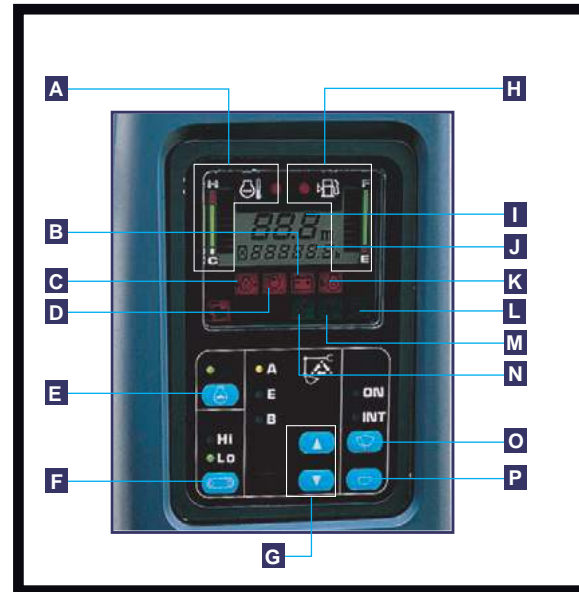

- A Engine Water Temperature
- B Battery Charge
- C Engine Oil Pressure
- D Air Cleaner Clogging Monitor
- E Auto-Decel Switch
- F Travel Speed Select Switch
- G Working Mode Select Switch
- H Fuel Level Monitor
- I User or Trouble Code Display
- J Service Meter Display
- K Engine Oil Level
- L Engine Preheat
- M Swing Lock Display
- N Oil Maintenance
- O Windshield Wiper Switch
- P Windshield Washer Switch

- Easy Access to Engine Oil Filter and Fuel Drain Valve**
 Engine oil filter and fuel drain valve are remotely mounted to improve accessibility.



Reducing Maintenance Costs

- Hydraulic Oil and Filter/Engine Oil and Filter Replacement Interval Extended**
 The new high performance filters are used in hydraulic circuit and engine. Hydraulic oil filter, engine oil, and engine oil filter element replacement intervals are significantly extended to reduce maintenance costs.

Comparison of Replacement Intervals unit: hours

	PC220-7	PC220-6
Engine oil	500	250
Engine oil filter	500	250
Hydraulic oil	5,000	5,000
Hydraulic oil filter	1,000	500

- Fuel Tank Capacity Increased**
 Fuel tank capacity is increased from 340 ltr 89.8 U.S. gal to 400 ltr 105.7 U.S. gal to extend operating hours before refueling. Fuel tank is treated for rust prevention and improved corrosion resistance.

OPTIONS TO UPDATE THE VALUE

Multi-Function Color Monitor

A newly developed Multi-Function Color Monitor has multiple functions, such as Working mode selection, hydraulic pump oil flow adjustment for matching to attachment, and maintenance interval notice, etc.

Working Mode Selection

The Multi-Function Color Monitor has **Lifting mode** in addition to the standard three-mode selection (A, E, and B modes).

Working Mode	Application	Advantage
A	Active mode	<ul style="list-style-type: none"> Maximum production/power Fast cycle times
E	Economy mode	<ul style="list-style-type: none"> Excellent fuel economy
L	Lifting mode	<ul style="list-style-type: none"> Hydraulic pressure is increased by 7%
B	Breaker operation	<ul style="list-style-type: none"> Optimum engine rpm, hydraulic flow

Hydraulic Pump Oil Flow Adjustment System

When installing attachments (breaker, crusher, etc.) and B, A, or E mode is selected, it is possible to adjust engine and hydraulic pump discharge flow to match attachment characteristics. Selection is possible throughout the LCD (Liquid Crystal Display). This system also allows throttling of the attachment side discharge flow to provide smooth work equipment movement and compound operation with work equipment and attachment.

All Work Equipment Lubrication Intervals Are 500 Hours with optional BMRC Bushings (except bucket pin bushings)

Newly developed BMRC bushings are used on the work equipment. All bushing lubrication intervals of work equipment are extended from 100 hours to 500 hours (except bucket pin bushings), reducing maintenance costs.

BMRC (Beta Matrix Reinforced Copper Alloy)

A bushing made by combining a sintered copper layer impregnated with oil for better fitting and a backing metal. It is used for severe application parts which receive low rocking stresses and high loads to prevent creaking and scuffing because of its excellent sliding characteristics.

Sintered Al bronze layer impregnated with high-performance lubricating oil

Backing metal (steel)

Automatic Three-Travel Speed

Travel speed is automatically shifted from high to low speed according to the pressure of the travel. This optional system is available as part of the Multi-Function Color Monitor.

	High	Mid	Low
Travel Speed	5.5 km/h 3.4 mph	4.2 km/h 2.6 mph	3.1 km/h 1.9 mph

Lifting Mode

When the Lifting mode is selected, lifting capacity is increased by 7% by raising hydraulic pressure.



EMMS (Equipment Management Monitoring System)

Monitor Function

Controller monitors engine oil level, coolant temperature, battery charge and air clogging, etc. If controller finds any abnormality, it is displayed on the LCD.

Maintenance Function

Monitor informs replacement time of oil and filters on LCD when the replacement interval is reached.

Trouble Data Memory Function

Monitor stores abnormalities for effective troubleshooting.

Work Equipment Lubrication Interval unit:hours

PC220-7	PC220-6
500	100

(except bucket pin bushings)

SPECIFICATIONS



ENGINE

Model Komatsu SAA6D102E-2
 Type Water-cooled, 4-cycle, direct injection
 Aspiration Turbocharged, aftercooled
 Number of cylinders 6
 Bore **102 mm** 4.02"
 Stroke **120 mm** 4.72"
 Piston displacement **5.88 ltr** 359 in³
 Flywheel horsepower:
 SAE J1349 **125 kW** 168 HP @ 2000 rpm
 DIN6270 **125 kW** 170 PS @ 2000 rpm
 Governor All-speed control, mechanical



HYDRAULICS

Type HydraMind (Hydraulic Mechanical Intelligence New Design) system, closed-center system with load sensing valves and pressure compensated valves
 Number of selectable working modes 3
 Main pump:
 Type Variable displacement piston type
 Pumps for Boom, arm, bucket, swing, and travel circuits
 Maximum flow **439 ltr/min** 116 U.S. gal/min
 Supply for control circuit Self-reducing valve
 Hydraulic motors:
 Travel 2 x axial piston motor with parking brake
 Swing 1 x axial piston motor with swing holding brake
 Relief valve setting:
 Implement circuits 37.3 MPa **380 kgf/cm²** 5,400 psi
 Travel circuit 37.3 MPa **380 kgf/cm²** 5,400 psi
 Swing circuit 28.4 MPa **290 kgf/cm²** 4,120 psi
 Pilot circuit 3.2 MPa **33 kgf/cm²** 470 psi
 Hydraulic cylinders:
 (Number of cylinders – bore x stroke x rod diameter)
 Boom **2–130 mm x 1335 mm x 90 mm** 5.1" x 52.6" x 3.5"
 Arm **1–140 mm x 1635 mm x 100 mm** 5.5" x 64.4" x 3.9"
 Bucket: for **2.5 m** 8'2" and **3.05 m** 10'0" Arm
 1–130 mm x 1020 mm x 90 mm 5.1" x 40.2" x 3.5"
 for **2.0 m** 6'7" Arm
 1–140 mm x 1009 mm x 100 mm 5.5" x 39.7" x 3.9"



DRIVES AND BRAKES

Steering control Two levers with pedals
 Drive method Hydrostatic
 Maximum drawbar pull 202 kN **20570 kg** 45,350 lb
 Gradeability 70%, 35°
 Maximum travel speed: High **5.5 km/h** 3.4 mph
 (Auto-Shift) Low **3.1 km/h** 1.9 mph
 Service brake Hydraulic lock
 Parking brake Mechanical disc brake



SWING SYSTEM

Drive method Hydrostatic
 Swing reduction Planetary gear
 Swing circle lubrication Grease-bathed
 Service brake Hydraulic lock
 Holding brake/Swing lock Mechanical disc brake
 Swing speed 11.7 rpm



UNDERCARRIAGE

Center frame X-frame
 Track frame Box-section
 Seal of track Sealed track
 Track adjuster Hydraulic
 Number of shoes (each side):
 PC220-7 47
 PC220LC-7 51
 Number of carrier rollers 2 each side
 Number of track rollers (each side):
 PC220-7 8
 PC220LC-7 10



COOLANT AND LUBRICANT CAPACITY (REFILLING)

Fuel tank **400 ltr** 105.7 U.S. gal
 Coolant **30.9 ltr** 8.2 U.S. gal
 Engine **24.0 ltr** 6.3 U.S. gal
 Final drive, each side **4.5 ltr** 1.2 U.S. gal
 Swing drive **6.6 ltr** 1.7 U.S. gal
 Hydraulic tank **143 ltr** 37.8 U.S. gal



OPERATING WEIGHT (APPROXIMATE)

Operating weight including **5850 mm** 19'2" one-piece boom, **3045 mm** 10'0" arm, SAE heaped **1.0 m³** 1.31 yd³ backhoe bucket, rated capacity of lubricants, coolant, full fuel tank, operator, and standard equipment.

Shoes	PC220-7		PC220LC-7	
	Operating Weight	Ground Pressure	Operating Weight	Ground Pressure
600 mm 23.6"	22840 kg 50,350 lb	50.0 kPa 0.51 kgf/cm² 7.25 psi	23990 kg 52,890 lb	48.1 kPa 0.49 kgf/cm² 6.97 psi
700 mm 27.6"	23100 kg 50,930 lb	43.1 kPa 0.44 kgf/cm² 6.26 psi	24270 kg 53,510 lb	41.2 kPa 0.42 kgf/cm² 5.97 psi
800 mm 31.5"	23360 kg 51,500 lb	38.2 kPa 0.39 kgf/cm² 5.55 psi	24550 kg 54,120 lb	36.3 kPa 0.37 kgf/cm² 5.26 psi



DIMENSIONS

	2000 mm 6'7"	2500 mm 8'2"	3045 mm 10'0"
A Overall length	9865 mm 32'4"	9960 mm 32'8"	9885 mm 32'5"
B Length on ground (transport): PC220-7 PC220LC-7	6470 mm 21'3" 6660 mm 21'10"	5920 mm 19'5" 6115 mm 20'1"	5190 mm 17'0" 5390 mm 17'8"
C Overall height (to top of boom)	3220 mm 10'7"	3295 mm 10'10"	3160 mm 10'4"

	PC220-7	PC220LC-7
D Overall width	2980 mm 9'9"	3280 mm 10'9"
E Overall height (to top of cab)	3015 mm 9'11"	3015 mm 9'11"
F Ground clearance, counterweight	1100 mm 3'7"	1100 mm 3'7"
G Ground clearance (minimum)	440 mm 1'5"	440 mm 1'5"
H Tail swing radius	2940 mm 9'8"	2940 mm 9'8"
I Track length on ground	3460 mm 11'4"	3845 mm 12'7"
J Track length	4265 mm 14'0"	4640 mm 15'3"
K Track gauge	2380 mm 7'10"	2580 mm 8'6"
L Width of crawler	2980 mm 9'9"	3280 mm 10'9"
M Shoe width	600 mm 23.6"	700 mm 27.6"
N Grouser height	26 mm 1.0"	26 mm 1.0"
O Machine cab height	2110 mm 6'11"	2110 mm 6'11"
P Machine cab width	2710 mm 8'11"	2710 mm 8'11"
Q Distance, swing center to rear end	2905 mm 9'6"	2905 mm 9'6"

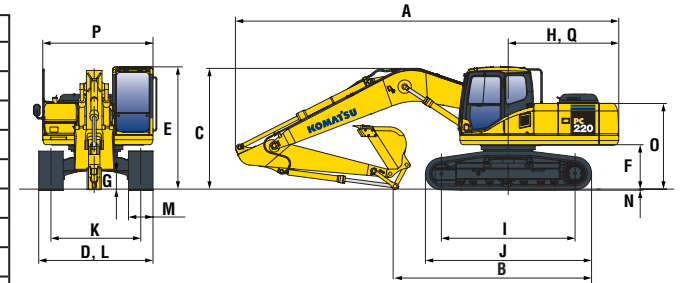

WORKING RANGE

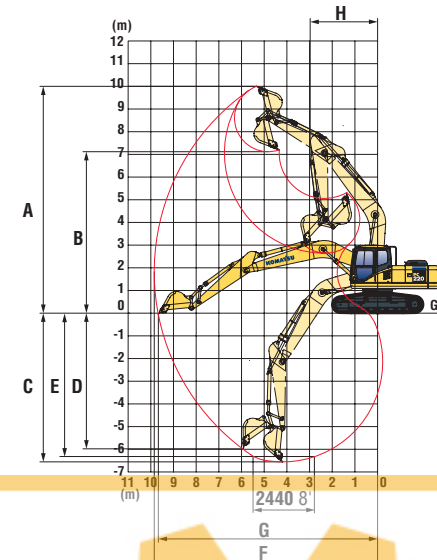

	2000 mm 6'7"	2500 mm 8'2"	3045 mm 10'0"
A Max. digging height	9665 mm 31'9"	9790 mm 32'1"	10000 mm 32'10"
B Max. dumping height	6715 mm 22'0"	6860 mm 22'6"	7035 mm 23'1"
C Max. digging depth	5825 mm 19'1"	6320 mm 20'9"	6920 mm 22'8"
D Max. vertical wall digging depth	4750 mm 15'7"	5130 mm 16'10"	6010 mm 19'9"
E Max. digging depth of cut for 8' level	5585 mm 18'4"	6100 mm 20'0"	6700 mm 22'0"
F Max. digging reach	9270 mm 30'5"	9670 mm 31'9"	10180 mm 33'5"
G Max. digging reach at ground level	9070 mm 29'9"	9480 mm 31'1"	10020 mm 32'10"
H Min. swing radius	3300 mm 10'10"	3320 mm 10'11"	3450 mm 11'4"
SAE rating	Bucket digging force at power max.	176 kN 17900 kgf/39,460 lb	152 kN 15500 kgf/34,170 lb
	Arm crowd force at power max.	155 kN 15800 kgf/34,830 lb	142 kN 14500 kgf/31,970 lb
ISO rating	Bucket digging force at power max.	197 kN 20100 kgf/44,310 lb	172 kN 17500 kgf/38,580 lb
	Arm crowd force at power max.	161 kN 16400 kgf/36,160 lb	148 kN 15100 kgf/33,290 lb



BACKHOE BUCKET, ARM, AND BOOM COMBINATION

Bucket Capacity (heaped)	Width		Weight	Number of Teeth	Arm Length		
	SAE, PCSA	CECE			Without Side Cutters	With Side Cutters	With Side Cutters
0.72 m ³ 0.94 yd ³	0.65 m ³ 0.85 yd ³	900 mm 35.4"	658 kg 1,450 lb	3	2.00 m 6'7"	2.50 m 8'2"	3.05 m 10'0"
1.00 m ³ 1.31 yd ³	0.90 m ³ 1.18 yd ³	1155 mm 45.5"	734 kg 1,620 lb	4	○	○	○
1.14 m ³ 1.49 yd ³	1.00 m ³ 1.31 yd ³	1300 mm 51.2"	793 kg 1,750 lb	5	○	□	□
1.26 m ³ 1.65 yd ³	1.10 m ³ 1.44 yd ³	1400 mm 55.1"	845 kg 1,860 lb	5	○	□	●

○ General purpose use, density up to 1.8 ton/m³ 1.52 U.S. ton/yd³ ● Light duty work, density up to 1.2 ton/m³ 1.01 U.S. ton/yd³
 □ General purpose use, density up to 1.5 ton/m³ 1.26 U.S. ton/yd³ ✕ Not usable

JC Machinery
 excavatorhunter.com

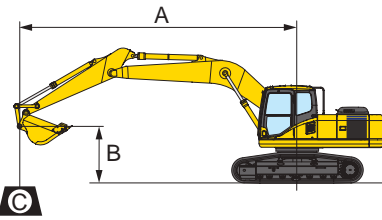

A: Reach from swing center
 B: Bucket hook height
 C: Lifting capacity
 Cf: Rating over front
 Cs: Rating over side
 ☉: Rating at maximum reach

Conditions:
 • 5850 mm 19'2" one-piece boom

PC220-7		Arm: 3045 mm 10'0"		Bucket: 1.0 m ³ 1.31 yd ³		Shoe: 600 mm 23.6" triple grouser							
B	A	☉ MAX		7.6 m 25'		6.1 m 20'		4.6 m 15'		3.0 m 10'		1.5 m 5'	
		Cf	Cs	Cf	Cs	Cf	Cs	Cf	Cs	Cf	Cs	Cf	Cs
7.6 m 25'		*2900 kg *6,400 lb	*2900 kg *6,400 lb			*3900 kg *8,700 lb	*3900 kg *8,700 lb						
6.1 m 20'		*2750 kg *6,100 lb	*2750 kg *6,100 lb	*3700 kg *8,200 lb	3500 kg 7,800 lb	*4100 kg *9,000 lb	*4100 kg *9,000 lb						
4.6 m 15'		*2800 kg *6,200 lb	2750 kg 6,000 lb	*4600 kg *10,100 lb	3450 kg 7,600 lb	*4800 kg *10,600 lb	*4800 kg *10,600 lb						
3.0 m 10'		*2950 kg *6,500 lb	2450 kg 5,500 lb	4900 kg 10,800 lb	3350 kg 7,400 lb	*5900 kg 13,000 lb	4900 kg 10,800 lb	*7450 kg *17,900 lb	*7450 kg *17,900 lb	*11800 kg *26,000 lb	*11800 kg *26,000 lb		
1.5 m 5'		*3250 kg *7,200 lb	2350 kg 5,200 lb	4750 kg 10,400 lb	3200 kg 7,000 lb	6850 kg 15,100 lb	4600 kg 10,100 lb	*9700 kg *21,400 lb	7150 kg 15,700 lb	*6850 kg *15,100 lb	*6850 kg *15,100 lb		
0 m 0'		3650 kg 8,100 lb	2400 kg 5,300 lb	4,600 kg 10,100 lb	3050 kg 6,700 lb	6550 kg 14,500 lb	4350 kg 9,600 lb	10500 kg 23,200 lb	6700 kg 14,800 lb	*7800 kg *17,100 lb	*7800 kg *17,100 lb		
-1.5 m -5'		4000 kg 8,800 lb	2600 kg 5,800 lb	4550 kg 10,000 lb	3000 kg 6,600 lb	6450 kg 14,200 lb	4200 kg 9,300 lb	10300 kg 22,700 lb	6550 kg 14,400 lb	*11150 kg *24,600 lb	11150 kg 24,600 lb	*6900 kg *15,200 lb	*6900 kg *15,200 lb
-3.0 m -10'		4700 kg 10,400 lb	3100 kg 6,900 lb			6400 kg 14,200 lb	4200 kg 9,300 lb	10350 kg 22,800 lb	6550 kg 14,500 lb	*16050 kg *35,400 lb	13100 kg 28,900 lb	*10750 kg *23,700 lb	*10750 kg *23,700 lb
-4.6 m -15'		6500 kg 14,300 lb	4300 kg 9,500 lb			6600 kg 14,500 lb	4350 kg 9,600 lb	*10400 kg 23,000 lb	6750 kg 14,900 lb	*15200 kg *33,500 lb	13500 kg 29,800 lb		

PC220-7		Arm: 2000 mm 6'7"		Bucket: 1.0 m ³ 1.31 yd ³		Shoe: 600 mm 23.6" triple grouser							
B	A	☉ MAX		7.6 m 25'		6.1 m 20'		4.6 m 15'		3.0 m 10'		1.5 m 5'	
		Cf	Cs	Cf	Cs	Cf	Cs	Cf	Cs	Cf	Cs	Cf	Cs
7.6 m 25'		*4750 kg *10,500 lb	*4750 kg *10,500 lb										
6.1 m 20'		*4500 kg *9,900 lb	4100 kg 9,100 lb			*5200 kg *11,400 lb	5100 kg 11,300 lb						
4.6 m 15'		*4550 kg *10,000 lb	3300 kg 7,300 lb			*5800 kg *12,800 lb	4950 kg 10,900 lb	*6850 kg *15,100 lb	*6850 kg *15,100 lb	*9750 kg *21,500 lb	*9750 kg *21,500 lb		
3.0 m 10'		4400 kg 9,700 lb	2950 kg 6,500 lb	4750 kg 10,400 lb	3200 kg 7,000 lb	*6750 kg *14,900 lb	4650 kg 10,300 lb	*8850 kg 19,500 lb	7100 kg 15,700 lb				
1.5 m 5'		4250 kg 9,400 lb	2800 kg 6,200 lb	4600 kg 10,200 lb	3050 kg 6,800 lb	6600 kg 14,600 lb	4400 kg 9,700 lb	10500 kg 23,100 lb	6700 kg 14,800 lb				
0 m 0'		4400 kg 9,700 lb	2900 kg 6,400 lb	4550 kg 10,000 lb	3000 kg 6,600 lb	6400 kg 14,200 lb	4200 kg 9,300 lb	10200 kg 22,500 lb	6450 kg 14,200 lb				
-1.5 m -5'		4900 kg 10,800 lb	3250 kg 7,100 lb			6350 kg 14,100 lb	4150 kg 9,200 lb	10200 kg 22,500 lb	6450 kg 14,200 lb	*13000 kg *28,600 lb	12900 kg 28,400 lb		
-3.0 m -10'		6200 kg 13,700 lb	4100 kg 9,100 lb			6500 kg 14,300 lb	4300 kg 9,400 lb	10400 kg 22,900 lb	6550 kg 14,600 lb	*15350 kg *33,900 lb	13250 kg 29,200 lb		
-4.6 m -15'		*8150 kg *17,900 lb	6800 kg 15,000 lb					*8350 kg *18,400 lb	7700 kg 15,500 lb				

PC220-7		Arm: 2500 mm 8'2"		Bucket: 1.0 m ³ 1.31 yd ³		Shoe: 600 mm 23.6" triple grouser							
B	A	☉ MAX		7.6 m 25'		6.1 m 20'		4.6 m 15'		3.0 m 10'		1.5 m 5'	
		Cf	Cs	Cf	Cs	Cf	Cs	Cf	Cs	Cf	Cs	Cf	Cs
7.6 m 25'		*4600 kg *10,100 lb	*4600 kg *10,100 lb			*4650 kg *10,200 lb	*4650 kg *10,200 lb						
6.1 m 20'		*4400 kg *9,700 lb	3750 kg 8,300 lb			*4650 kg *10,300 lb	*4650 kg *10,300 lb						
4.6 m 15'		*4450 kg *9,800 lb	3100 kg 6,800 lb	4950 kg 10,900 lb	3350 kg 7,400 lb	*5350 kg *11,700 lb	5050 kg 11,100 lb	*6100 kg *13,500 lb	*6100 kg *13,500 lb				
3.0 m 10'		4100 kg 9,100 lb	2750 kg 6,100 lb	4800 kg 10,600 lb	3250 kg 7,200 lb	*6350 kg *14,000 lb	4750 kg 10,500 lb	8250 kg 18,200 lb	7500 kg 16,600 lb				
1.5 m 5'		3950 kg 8,700 lb	2600 kg 5,800 lb	4650 kg 10,300 lb	3100 kg 6,900 lb	6700 kg 14,800 lb	4450 kg 9,900 lb	*10300 kg *22,700 lb	6900 kg 15,200 lb				
0 m 0'		4050 kg 9,000 lb	2700 kg 5,900 lb	4550 kg 10,000 lb	3000 kg 6,600 lb	6450 kg 14,300 lb	4250 kg 9,400 lb	10300 kg 22,800 lb	6550 kg 14,500 lb	*7250 kg *16,000 lb	*7250 kg *16,000 lb		
-1.5 m -5'		4500 kg 9,900 lb	2950 kg 6,500 lb	4500 kg 10,000 lb	3000 kg 6,600 lb	6400 kg 14,100 lb	4200 kg 9,200 lb	10200 kg 22,500 lb	6450 kg 14,300 lb	*12450 kg *27,400 lb	*12450 kg *27,400 lb	*8000 kg *17,700 lb	*8000 kg *17,700 lb
-3.0 m -10'		5500 kg 12,100 lb	3650 kg 8,000 lb			6450 kg 14,200 lb	4250 kg 9,300 lb	10350 kg 22,800 lb	6550 kg 14,500 lb	*16450 kg *36,300 lb	13100 kg 28,900 lb	*13150 kg *29,000 lb	*13150 kg *29,000 lb
-4.6 m -15'		*8000 kg *17,600 lb	5500 kg 12,100 lb			*9350 kg *20,600 lb	6650 kg 14,700 lb	*13700 kg *30,200 lb	13650 kg 30,100 lb				

* Load is limited by hydraulic capacity rather than tipping. Ratings are based on SAE Standard No. J1097. Rated loads do not exceed 87% of hydraulic lift capacity or 75% of tipping load.

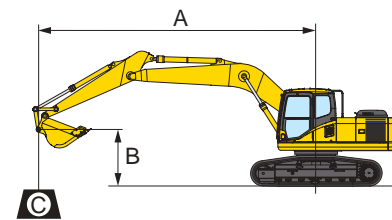

A: Reach from swing center
 B: Bucket hook height
 C: Lifting capacity
 Cf: Rating over front
 Cs: Rating over side
 ☉: Rating at maximum reach

Conditions:
 • 5850 mm 19'2" one-piece boom

PC220LC-7		Arm: 3045 mm 10'0"		Bucket: 1.0 m ³ 1.31 yd ³		Shoe: 700 mm 27.6" triple grouser							
B	A	☉ MAX		7.6 m 25'		6.1 m 20'		4.6 m 15'		3.0 m 10'		1.5 m 5'	
		Cf	Cs	Cf	Cs	Cf	Cs	Cf	Cs	Cf	Cs	Cf	Cs
7.6 m 25'		*2900 kg *6,400 lb	*2900 kg *6,400 lb			*3900 kg *8,700 lb	*3900 kg *8,700 lb						
6.1 m 20'		*2750 kg *6,100 lb	*2750 kg *6,100 lb	*3700 kg *8,200 lb	*3700 kg *8,200 lb	*4100 kg *9,000 lb	*4100 kg *9,000 lb						
4.6 m 15'		*2800 kg *6,200 lb	*2800 kg *6,200 lb	*4600 kg *10,100 lb	4000 kg 8,800 lb	*4800 kg *10,600 lb	*4800 kg *10,600 lb						
3.0 m 10'		*2950 kg *6,500 lb	2900 kg 6,400 lb	*5150 kg *11,400 lb	3850 kg 8,500 lb	*5900 kg 13,000 lb	5650 kg 12,400 lb	*7450 kg *16,500 lb	*7450 kg *16,500 lb	*11800 kg *26,000 lb	*11800 kg *26,000 lb		
1.5 m 5'		*3250 kg *7,200 lb	2800 kg 6,200 lb	*5800 kg *12,800 lb	3700 kg 8,200 lb	*7050 kg *15,500 lb	5350 kg 11,700 lb	*9700 kg *21,400 lb	8300 kg 18,300 lb	*6850 kg *15,100 lb	*6850 kg *15,100 lb		
0 m 0'		*3750 kg *8,300 lb	2850 kg 6,300 lb	5650 kg 12,500 lb	3600 kg 7,900 lb	*8000 kg *17,600 lb	5100 kg 11,200 lb	*11200 kg *24,700 lb	7900 kg 17,400 lb	*7800 kg *17,100 lb	*7800 kg *17,100 lb		
-1.5 m -5'		*4600 kg *10,100 lb	3100 kg 6,800 lb	5600 kg 12,300 lb	3500 kg 7,800 lb	7950 kg 17,500 lb	4950 kg 10,900 lb	*11800 kg *26,100 lb	7700 kg 17,000 lb	*11150 kg *24,600 lb	11150 kg 24,600 lb	*6900 kg *15,200 lb	*6900 kg *15,200 lb
-3.0 m -10'		5800 kg 12,800 lb	3650 kg 8,100 lb			7950 kg 17,500 lb	4950 kg 10,900 lb	*16050 kg *35,400 lb	15700 kg 34,600 lb	*10750 kg *23,700 lb	*10750 kg *23,700 lb		
-4.6 m -15'		*7250 kg *16,000 lb	5050 kg 11,100 lb			*7400 kg *16,300 lb	5100 kg 11,300 lb	*10400 kg *23,000 lb	7950 kg 17,500 lb	*15200 kg *33,500 lb	*15200 kg *33,500 lb		

PC220LC-7		Arm: 2000 mm 6'7"		Bucket: 1.0 m ³ 1.31 yd ³		Shoe: 700 mm 27.6" triple grouser							
B	A	☉ MAX		7.6 m 25'		6.1 m 20'		4.6 m 15'		3.0 m 10'		1.5 m 5'	
		Cf	Cs	Cf	Cs	Cf	Cs	Cf	Cs	Cf	Cs	Cf	Cs
7.6 m 25'		*4750 kg *10,500 lb	*4750 kg *10,500 lb										
6.1 m 20'		*4500 kg *9,900 lb	4100 kg 9,100 lb			*5200 kg *11,400 lb	*5200 kg *11,400 lb						
4.6 m 15'		*4550 kg *10,000 lb	3850 kg 8,500 lb			*5800 kg *12,800 lb	5700 kg 12,500 lb	*6850 kg *15,100 lb	*6850 kg *15,100 lb	*9750 kg *21,500 lb	*9750 kg *21,500 lb		
3.0 m 10'		*4800 kg *10,600 lb	3700 kg 8,200 lb	*5800 kg *12,800 lb	3700 kg 8,200 lb	*6750 kg *14,900 lb	5400 kg 11,900 lb	*8850 kg *19,500 lb	8300 kg 18,300 lb				
1.5 m 5'		5200 kg 11,500 lb	3300 kg 7,300 lb	5650 kg 12,500 lb	3600 kg 7,900 lb	*7700 kg *17,000 lb	5100 kg 11,300 lb	*10800 kg *23,800 lb	7850 kg 17,300 lb				
0 m 0'		5400 kg 11,900 lb	3400 kg 7,500 lb	5600 kg 12,300 lb	3500 kg 7,700 lb	7950 kg 17,500 lb	4950 kg 10,900 lb	*11650 kg *25,700 lb	7600 kg 16,800 lb	*11650 kg *25,700 lb	7600 kg 16,800 lb		
-1.5 m -5'		6050 kg 13,300 lb	3800 kg 8,400 lb			7900 kg 17,400 lb	4900 kg 10,800 lb	*11650 kg *25,700 lb	7600 kg 16,800 lb	*13000 kg *28,600 lb	*13000 kg *28,600 lb		
-3.0 m -10'		*7550 kg *16,600 lb	4800 kg 10,600 lb			7850 kg 17,300 lb	5000 kg 11,100 lb	*10850 kg *23,900 lb	7750 kg 17,100 lb	*15350 kg *33,900 lb	*15350 kg *33,900 lb		
-4.6 m -15'		*8150 kg *17,900 lb	7950 kg 17,500 lb					*8350 kg *18,400 lb	8200 kg 18,000 lb				

PC220LC-7		Arm: 2500 mm 8'2"		Bucket: 1.0 m ³ 1.31 yd ³		Shoe: 700 mm 27.6" triple grouser							
B	A	☉ MAX		7.6 m 25'		6.1 m 20'		4.6 m 15'		3.0 m 10'		1.5 m 5'	
		Cf	Cs	Cf	Cs	Cf	Cs	Cf	Cs	Cf	Cs	Cf	Cs
7.6 m 25'		*4600 kg *10,100 lb	*4600 kg *10,100 lb			*4650 kg *10,200 lb	*4650 kg *10,200 lb						
6.1 m 20'		*4400 kg *9,700 lb	4350 kg 9,600 lb			*4650 kg *10,300 lb	*4650 kg *10,300 lb						
4.6 m 15'		*4450 kg *9,800 lb	3600 kg 7,900 lb	*5000 kg *11,100 lb	3900 kg 8,600 lb	*5350 kg *11,700 lb	*5350 kg *11,700 lb	*6100 kg *13,500 lb	*6100 kg *13,500 lb				

LIFTING CAPACITY WITH LIFTING MODE ON MULTI-FUNCTION COLOR MONITOR

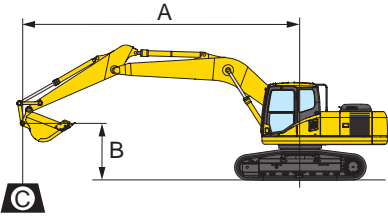

A: Reach from swing center
 B: Bucket hook height
 C: Lifting capacity
 Cf: Rating over front
 Cs: Rating over side
 ⊗: Rating at maximum reach

Conditions:
 • 5850 mm 19'2" one-piece boom

PC220-7 Arm: 3045 mm 10'0" Bucket: 1.0 m³ 1.31 yd³ Shoe: 600 mm 23.6" triple grouser												
A \ B	⊗ MAX		7.6 m 25'		6.1 m 20'		4.6 m 15'		3.0 m 10'		1.5 m 5'	
	Cf	Cs	Cf	Cs	Cf	Cs	Cf	Cs	Cf	Cs	Cf	Cs
7.6 m 25'	*3150 kg *7,000 lb	*3150 kg *7,000 lb			*4300 kg *9,500 lb	*4300 kg *9,500 lb						
6.1 m 20'	*3050 kg *6,700 lb	*3050 kg *6,700 lb	*4050 kg *8,900 lb	3500 kg 7,800 lb	*4500 kg *9,900 lb	*4500 kg *9,900 lb						
4.6 m 15'	*3050 kg *6,700 lb	2750 kg 6,000 lb	5050 kg 11,100 lb	3450 kg 7,600 lb	*5250 kg *11,600 lb	5200 kg 11,400 lb						
3.0 m 10'	*3250 kg *7,100 lb	2450 kg 5,400 lb	4900 kg 10,800 lb	3350 kg 7,400 lb	*6450 kg *14,200 lb	4900 kg 10,800 lb	*8150 kg *17,900 lb	7800 kg 17,200 lb	*12850 kg *28,300 lb	*12850 kg *28,300 lb		
1.5 m 5'	*3550 kg *7,800 lb	2350 kg 5,200 lb	4750 kg 10,400 lb	3200 kg 7,000 lb	6850 kg 15,100 lb	4600 kg 10,100 lb	*10550 kg *23,300 lb	7150 kg 15,700 lb	*7400 kg *16,300 lb	*7400 kg *16,300 lb		
0 m 0'	3650 kg 8,100 lb	2400 kg 5,300 lb	4600 kg 10,100 lb	3050 kg 6,700 lb	6550 kg 14,500 lb	4350 kg 9,600 lb	10500 kg 23,200 lb	6700 kg 14,800 lb	*8400 kg *18,500 lb	*8400 kg *18,500 lb		
-1.5 m -5'	4000 kg 8,800 lb	2600 kg 5,800 lb	4550 kg 10,000 lb	3000 kg 6,600 lb	6450 kg 14,200 lb	4200 kg 9,300 lb	10300 kg 22,700 lb	6550 kg 14,400 lb	*12000 kg *26,400 lb	*12000 kg *26,400 lb	*7450 kg *16,400 lb	*7450 kg *16,400 lb
-3.0 m -10'	4700 kg 10,400 lb	3100 kg 6,900 lb			6400 kg 14,200 lb	4200 kg 9,300 lb	10350 kg 22,800 lb	6550 kg 14,400 lb	*17300 kg *38,100 lb	13100 kg 28,900 lb	*11150 kg *25,500 lb	*11150 kg *25,500 lb
-4.6 m -15'	6500 kg 14,300 lb	4300 kg 9,500 lb			6600 kg 14,500 lb	4350 kg 9,600 lb	10550 kg 23,300 lb	6750 kg 14,900 lb	*16550 kg *36,500 lb	13500 kg 29,800 lb		

PC220-7 Arm: 2000 mm 6'7" Bucket: 1.0 m³ 1.31 yd³ Shoe: 600 mm 23.6" triple grouser												
A \ B	⊗ MAX		7.6 m 25'		6.1 m 20'		4.6 m 15'		3.0 m 10'		1.5 m 5'	
	Cf	Cs	Cf	Cs	Cf	Cs	Cf	Cs	Cf	Cs	Cf	Cs
7.6 m 25'	*5150 kg *11,400 lb	*5150 kg *11,400 lb										
6.1 m 20'	*4850 kg *10,700 lb	4100 kg 9,100 lb			*5700 kg *12,500 lb	5100 kg 11,300 lb						
4.6 m 15'	4900 kg 10,800 lb	3300 kg 7,300 lb			*6350 kg *14,000 lb	4950 kg 10,900 lb	*7450 kg *16,500 lb	*7450 kg *16,500 lb	*10600 kg *23,400 lb	*10600 kg *23,400 lb		
3.0 m 10'	4400 kg 9,700 lb	2950 kg 6,500 lb	4750 kg 10,400 lb	3200 kg 7,000 lb	6900 kg 15,200 lb	4650 kg 10,300 lb	*9650 kg *21,300 lb	7100 kg 15,700 lb				
1.5 m 5'	4250 kg 9,400 lb	2800 kg 6,200 lb	4600 kg 10,200 lb	3050 kg 6,800 lb	6600 kg 14,600 lb	4400 kg 9,700 lb	10500 kg 23,100 lb	6700 kg 14,800 lb				
0 m 0'	4400 kg 9,700 lb	2900 kg 6,400 lb	4550 kg 10,000 lb	3000 kg 6,600 lb	6400 kg 14,200 lb	4200 kg 9,300 lb	10200 kg 22,500 lb	6450 kg 14,200 lb				
-1.5 m -5'	4900 kg 10,800 lb	3250 kg 7,100 lb			6350 kg 14,100 lb	4150 kg 9,200 lb	10200 kg 22,500 lb	6450 kg 14,200 lb	*13950 kg *30,800 lb	12900 kg 28,400 lb		
-3.0 m -10'	6200 kg 13,700 lb	4100 kg 9,100 lb			6500 kg 14,300 lb	4300 kg 9,400 lb	10400 kg 22,900 lb	6600 kg 14,600 lb	*16750 kg *36,900 lb	13250 kg 29,200 lb		
-4.6 m -15'	*8900 kg *19,500 lb	6800 kg 15,000 lb					*9100 kg *20,100 lb	7000 kg 15,500 lb				

PC220-7 Arm: 2500 mm 8'2" Bucket: 1.0 m³ 1.31 yd³ Shoe: 600 mm 23.6" triple grouser												
A \ B	⊗ MAX		7.6 m 25'		6.1 m 20'		4.6 m 15'		3.0 m 10'		1.5 m 5'	
	Cf	Cs	Cf	Cs	Cf	Cs	Cf	Cs	Cf	Cs	Cf	Cs
7.6 m 25'	*4950 kg *11,000 lb	*4950 kg *11,000 lb			*5000 kg *11,100 lb	*5000 kg *11,100 lb						
6.1 m 20'	*4750 kg *10,500 lb	3750 kg 8,300 lb			*5100 kg *11,300 lb	*5100 kg *11,300 lb						
4.6 m 15'	4550 kg 10,000 lb	3100 kg 6,800 lb	4950 kg 10,900 lb	3350 kg 7,400 lb	*5850 kg *12,900 lb	5050 kg 11,100 lb	*6650 kg *14,700 lb	*6650 kg *14,700 lb				
3.0 m 10'	4100 kg 9,100 lb	2750 kg 6,100 lb	4800 kg 10,600 lb	3250 kg 7,200 lb	*6950 kg *15,300 lb	4750 kg 10,500 lb	*9000 kg *19,900 lb	7500 kg 16,600 lb				
1.5 m 5'	3950 kg 8,700 lb	2600 kg 5,800 lb	4650 kg 10,300 lb	3100 kg 6,900 lb	6700 kg 14,800 lb	4450 kg 9,900 lb	10700 kg 23,600 lb	6900 kg 15,200 lb				
0 m 0'	4050 kg 9,000 lb	2700 kg 5,900 lb	4550 kg 10,000 lb	3000 kg 6,600 lb	6450 kg 14,300 lb	4250 kg 9,400 lb	10300 kg 22,800 lb	6550 kg 14,500 lb	*7850 kg *17,300 lb	*7850 kg *17,300 lb		
-1.5 m -5'	4500 kg 9,900 lb	2950 kg 6,500 lb	4500 kg 10,000 lb	3000 kg 6,600 lb	6400 kg 14,100 lb	4200 kg 9,200 lb	10200 kg 22,500 lb	6450 kg 14,300 lb	*13400 kg *29,500 lb	12850 kg 28,300 lb	*8650 kg *19,000 lb	*8650 kg *19,000 lb
-3.0 m -10'	5500 kg 12,100 lb	3650 kg 8,000 lb			6450 kg 14,200 lb	4250 kg 9,300 lb	10350 kg 22,800 lb	6550 kg 14,500 lb	*17900 kg *39,500 lb	13100 kg 28,900 lb	*14150 kg *31,200 lb	*14150 kg *31,200 lb
-4.6 m -15'	8350 kg 18,400 lb	5500 kg 12,100 lb					*10250 kg *22,600 lb	6650 kg 14,700 lb	*14950 kg *32,900 lb	13650 kg 30,100 lb		

* Load is limited by hydraulic capacity rather than tipping. Ratings are based on SAE Standard No. J1097. Rated loads do not exceed 87% of hydraulic lift capacity or 75% of tipping load.

LIFTING CAPACITY WITH LIFTING MODE ON MULTI-FUNCTION COLOR MONITOR

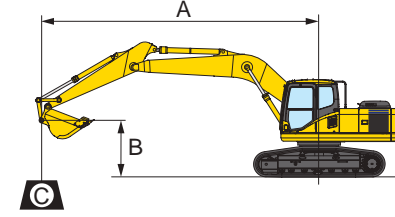

A: Reach from swing center
 B: Bucket hook height
 C: Lifting capacity
 Cf: Rating over front
 Cs: Rating over side
 ⊗: Rating at maximum reach

Conditions:
 • 5850 mm 19'2" one-piece boom

PC220LC-7 Arm: 3045 mm 10'0" Bucket: 1.0 m³ 1.31 yd³ Shoe: 700 mm 27.6" triple grouser												
A \ B	⊗ MAX		7.6 m 25'		6.1 m 20'		4.6 m 15'		3.0 m 10'		1.5 m 5'	
	Cf	Cs	Cf	Cs	Cf	Cs	Cf	Cs	Cf	Cs	Cf	Cs
7.6 m 25'	*3150 kg *7,000 lb	*3150 kg *7,000 lb			*4300 kg *9,500 lb	*4300 kg *9,500 lb						
6.1 m 20'	*3050 kg *6,700 lb	*3050 kg *6,700 lb	*4050 kg *8,900 lb	3500 kg 7,800 lb	*4500 kg *9,900 lb	*4500 kg *9,900 lb						
4.6 m 15'	*3050 kg *6,700 lb	*3050 kg *6,700 lb	*5050 kg *11,100 lb	4000 kg 8,800 lb	*5250 kg *11,600 lb	*5250 kg *11,600 lb						
3.0 m 10'	*3250 kg *7,100 lb	2900 kg 6,400 lb	*5650 kg *12,500 lb	3850 kg 8,500 lb	*6450 kg *14,200 lb	5650 kg 12,400 lb	*8150 kg *17,900 lb	*8150 kg *17,900 lb	*12850 kg *28,300 lb	*12850 kg *28,300 lb		
1.5 m 5'	*3550 kg *7,800 lb	2800 kg 6,200 lb	5800 kg 12,800 lb	3700 kg 8,200 lb	*7700 kg *17,000 lb	5350 kg 11,700 lb	*10550 kg *23,300 lb	8300 kg 18,300 lb	*7400 kg *16,300 lb	*7400 kg *16,300 lb		
0 m 0'	*4050 kg *9,000 lb	2850 kg 6,300 lb	5650 kg 12,500 lb	3600 kg 7,900 lb	*8100 kg *17,900 lb	5100 kg 11,200 lb	*12200 kg *26,900 lb	7900 kg 17,400 lb	*8400 kg *18,500 lb	*8400 kg *18,500 lb		
-1.5 m -5'	4900 kg 10,800 lb	3100 kg 6,800 lb	5600 kg 12,300 lb	3500 kg 7,800 lb	7950 kg 17,500 lb	4950 kg 10,900 lb	*12900 kg *28,400 lb	7700 kg 17,000 lb	*12000 kg *26,400 lb	12000 kg 26,400 lb	*7450 kg *16,400 lb	*7450 kg *16,400 lb
-3.0 m -10'	5800 kg 12,800 lb	3650 kg 8,100 lb			7950 kg 17,500 lb	4950 kg 10,900 lb	*12700 kg *28,000 lb	7750 kg 17,000 lb	*17300 kg *38,100 lb	15700 kg 34,600 lb	*11500 kg *25,500 lb	*11500 kg *25,500 lb
-4.6 m -15'	*7950 kg *17,600 lb	5050 kg 11,100 lb			*8100 kg *17,800 lb	5100 kg 11,300 lb	*11350 kg *25,100 lb	7950 kg 17,500 lb	*16550 kg *36,500 lb	16150 kg 35,600 lb		

PC220LC-7 Arm: 2000 mm 6'7" Bucket: 1.0 m³ 1.31 yd³ Shoe: 700 mm 27.6" triple grouser												
A \ B	⊗ MAX		7.6 m 25'		6.1 m 20'		4.6 m 15'		3.0 m 10'		1.5 m 5'	
	Cf	Cs	Cf	Cs	Cf	Cs	Cf	Cs	Cf	Cs	Cf	Cs
7.6 m 25'	*5150 kg *11,400 lb	*5150 kg *11,400 lb										
6.1 m 20'	*4850 kg *10,700 lb	4100 kg 9,100 lb			*5700 kg *12,500 lb	5100 kg 11,300 lb						
4.6 m 15'	4900 kg 10,800 lb	3850 kg 8,500 lb			*6350 kg *14,000 lb	4950 kg 10,900 lb	*7450 kg *16,500 lb	*7450 kg *16,500 lb	*10600 kg *23,400 lb	*10600 kg *23,400 lb		
3.0 m 10'	*5200 kg *11,500 lb	3450 kg 7,600 lb	*5800 kg *12,800 lb	3700 kg 8,200 lb	*7350 kg *16,300 lb	5400 kg 11,900 lb	*9650 kg *21,300 lb	8300 kg 18,300 lb				
1.5 m 5'	5200 kg 11,500 lb	3300 kg 7,300 lb	5650 kg 12,500 lb	3600 kg 7,900 lb	8150 kg 18,000 lb	5100 kg 11,300 lb	*11750 kg *25,900 lb	7850 kg 17,300 lb				
0 m 0'	5400 kg 11,900 lb	3400 kg 7,500 lb	5600 kg 12,300 lb	3500 kg 7,700 lb	7950 kg 17,500 lb	4950 kg 10,900 lb	*12700 kg *28,000 lb	7600 kg 16,800 lb				
-1.5 m -5'	6050 kg 13,300 lb	3800 kg 8,400 lb			7900 kg 17,400 lb	4900 kg 10,800 lb	*12700 kg *28,000 lb	7600 kg 16,800 lb	*13950 kg *30,800 lb	*13950 kg *30,800 lb		
-3.0 m -10'	7650 kg 16,600 lb	4800 kg 10,600 lb			8050 kg 17,700 lb	5000 kg 11,100 lb	*11800 kg *26,100 lb	7750 kg 17,100 lb	*16750 kg *36,900 lb	15850 kg 34,900 lb		
-4.6 m -15'	*8900 kg *19,600 lb	7950 kg 17,500 lb					*9100 kg *20,100 lb	8200 kg 18,000 lb				

PC220LC-7 Arm: 2500 mm 8'2" Bucket: 1.0 m³ 1.31 yd³ Shoe: 700 mm 27.6" triple grouser												
A \ B	⊗ MAX		7.6 m 25'		6.1 m 20'		4.6 m 15'		3.0 m 10'		1.5 m 5'	
	Cf	Cs	Cf	Cs	Cf	Cs	Cf	Cs	Cf	Cs	Cf	Cs
7.6 m 25'	*4950 kg *11,000 lb	*4950 kg *11,000 lb			*5000 kg *11,100 lb	*5000 kg *11,100 lb						
6.1 m 20'	*4750 kg *10,500 lb	4350 kg 9,600 lb			*5100 kg *11,300 lb	*5100 kg *11,300 lb						
4.6 m 15'	*4850 kg *10,700 lb	3600 kg 7,900 lb	*5500 kg *12,200 lb	3900 kg 8,600 lb	*5850 kg *12,900 lb	5800 kg 12,800 lb	*6650 kg *14,700 lb	*6650 kg *14,700 lb				
3.0 m 10'	5050 kg 11,100 lb	3250 kg 7,100 lb	5900 kg 13,000 lb	3800 kg 8,400 lb	*6950 kg *15,300 lb	5500 kg 12,100 lb	*9000 kg *19,900 lb	8700 kg 19,200 lb				
1.5 m 5'	4850 kg 10,800 lb	3100 kg 6,800 lb	5700 kg 12,600 lb	3650 kg 8,000 lb	*8100 kg *17,900 lb	5200 kg 11,500 lb	*11200 kg *24,800 lb	8050 kg 17,800 lb				
0 m 0'	5000 kg 11,100 lb	3150 kg 7,000 lb	5600 kg 12,400 lb	3550 kg 7,800 lb	8000 kg 17,600 lb	5000 kg 11,000 lb	*12500 kg *27,600 lb	7700 kg 17,000 lb	*7850 kg *17,300 lb	*785		



STANDARD EQUIPMENT

- Alternator, **35 Ampere**, 24V
- Auto-Decel
- Automatic engine warm-up system
- Automatic de-aeration system for fuel line
- Batteries, **110 Ah/2 x 12V**
- Boom holding valve
- Cab, capable FOG with optional bolt-on top guard
- Counterweight
- Dry type air cleaner, double element
- Electric horn
- Engine, Komatsu SAA6D102E
- Engine overheat prevention system
- Fan guard structure
- Hydraulic track adjusters (each side)
- Monitor panel, 7-segment
- Power maximizing system
- PPC hydraulic control system
- Radiator & oil cooler dust proof net
- Rear view mirror, R.H.
- Starting motor, **4.5 kW/24 v x 1**
- Suction fan
- Track guiding guard, center section
- Track roller
 - PC220-7, 8 each side
 - PC220LC-7, 10 each side
- Track shoe
 - PC220-7, **600 mm 24"** triple grouser
 - PC220LC-7, **700 mm 28"** triple grouser
- Working light, 2 (boom and RH)
- Working mode selection system



OPTIONAL EQUIPMENT

- Air conditioner with defroster
- Alternator, **60 ampere**, 24 v
- Arms
 - 3045 mm** 10'0" arm assembly
 - 2500 mm** 8'2" arm assembly
 - 2000 mm** 6'7" arm assembly
- Batteries, large capacity
- Bolt-on top guard OPG level 2 (FOG)
- Boom, **5850 mm** 19'2"
- Cab accessories
 - Rain visor
 - Sun visor
- Cab front guard
 - Full height guard
 - Half height guard
- Heater with defroster
- Long lubricating intervals for implement bushing (500 hours)
- Multi-Function Color Monitor
- Rearview mirror (LH)
- Seat belt, retractable
- Seat, suspension
- Service valve
- Shoes, triple grouser shoes
 - PC220-7
 - 700 mm** 27.6",
 - 800 mm** 31.5"
 - PC220LC-7
 - 600 mm** 23.6", **800 mm** 31.5"
- Starting motor, **5.5 kW/24 v x 1**
- Track roller guards (full length)
- Track frame undercover
- Travel alarm
- Working lights (2 on cab)



SPECIAL PURPOSE BUCKET

- **Ditch cleaning bucket**
 - Capacity
 - SAE heaped **0.80 m³** 1.05 yd³
 - CECE heaped **0.70 m³** 0.92 yd³
 - Width **1800 mm** 70.9"
- **Slope finishing bucket** for scraping slopes of banks
 - Capacity
 - SAE heaped **0.4 m³** 0.52 yd³
 - CECE heaped **0.35 m³** 0.46 yd³
 - Width **2000 mm** 78.7"
- **Trapezoidal bucket** is ideal for digging ditches and for drainage works
 - Capacity
 - SAE heaped **0.7 m³** 0.92 yd³
 - CECE heaped **0.5 m³** 0.65 yd³
- **Ripper bucket** for hard and rocky ground
 - Capacity
 - SAE heaped **0.62 m³** 0.81 yd³
 - CECE heaped **0.56 m³** 0.73 yd³
 - Width **990 mm** 39.0"
- **Single-shank ripper** and **three-shank ripper** are recommended for rock-digging and crushing, hard soil digging, pavement-removal works, etc.

www.Komatsu.com

KOMATSU[®]

Printed in Japan 200808 IP.As(10)

JC Machinery

SUNIGHT

excavatorhunter.com

CEN00045-03

Materials and specifications are subject to change without notice.

KOMATSU is a trademark of Komatsu Ltd. Japan.